

Our associates will ensure the tool works properly before you leave the store. If you experience issues with the tool while completing your project, simply bring it back to the Tool Rental Center to get a replacement. If you purchase Damage Protection at the time of your rental, you are not responsible for repair costs for tools that break due to normal use.



Before returning this product call

1-800-4-DEWALT

IF YOU SHOULD EXPERIENCE A PROBLEM WITH YOUR DEWALT PURCHASE,

CALL 1-800-4-DEWALT

IN MOST CASES, A DEWALT REPRESENTATIVE CAN RESOLVE
YOUR PROBLEM OVER THE PHONE.

IF YOU HAVE A SUGGESTION OR COMMENT, GIVE US A CALL.
YOUR FEEDBACK IS VITAL TO THE SUCCESS OF DEWALT'S
QUALITY IMPROVEMENT PROGRAM.

Questions? Visit us at www.dewalt.com

INSTRUCTION MANUAL

DEWALT®

DWS780

12" (305 mm) Double Bevel Sliding Compound Miter Saw

Scie coulissante à onglet mixte 305 mm (12 po)

**Sierra ingletadora compuesta deslizante de doble bisel de
305 mm (12 pulg.)**

Definitions: Safety Guidelines

The definitions below describe the level of severity for each signal word. Please read the manual and pay attention to these symbols.

⚠ DANGER: Indicates an imminently hazardous situation which, if not avoided, **will** result in **death or serious injury**.

⚠ WARNING: Indicates a potentially hazardous situation which, if not avoided, **could** result in **death or serious injury**.

⚠ CAUTION: Indicates a potentially hazardous situation which, if not avoided, **may** result in **minor or moderate injury**.

NOTICE: Indicates a practice **not related to personal injury** which, if not avoided, **may** result in **property damage**.

IF YOU HAVE ANY QUESTIONS OR COMMENTS ABOUT THIS OR ANY DEWALT TOOL, CALL US TOLL FREE AT: **1-800-4-DEWALT (1-800-433-9258)**.

IMPORTANT SAFETY INSTRUCTIONS



WARNING: Read all instructions before operating product. Failure to follow all instructions listed below may result in electric shock, fire and/or serious injury.

READ ALL INSTRUCTIONS

Double Insulation

Double insulated tools are constructed throughout with two separate layers of electrical insulation or one single layer of reinforced insulation between you and the tool's electrical system. Tools built with this insulation system are not intended to be grounded. As a result, your tool is equipped with a two prong plug which permits you to use extension cords without concern for maintaining a ground connection.

NOTE: Double insulation does not take the place of normal safety precautions when operating this tool. The secondary insulation system is for protection against injury resulting from a possible failure of the primary insulation within the tool.

⚠ CAUTION: WHEN SERVICING USE ONLY IDENTICAL REPLACEMENT PARTS. Repair or replace damaged cords.

Polarized Plugs

Polarized plugs (one blade is wider than the other) are used on equipment to reduce the risk of electric shock. When provided, this plug will fit in the polarized outlet only one way. If the plug does not fit fully in the outlet, reverse the plug. If it still does not fit, contact a qualified electrician to install the proper outlet. Do not change the plug in any way.

Drive

120 volt motor	
1600 watts in	15 amp motor
3800 RPM	Cut helical gears
Multi-V belt	Roller bearings
Automatic electric brake	Carbide blade

Safety Instructions for All Tools

⚠ WARNING: To reduce the risk of eye injury, **ALWAYS** use eye protection when operating the miter saw.

- **KEEP GUARD IN PLACE** and in working order.
- **REMOVE ADJUSTING KEYS AND WRENCHES.** Form habit of checking to see that keys and adjusting wrenches are removed from spindle before turning tool on. Tools, scrap pieces, and other debris can be thrown at high speed, causing injury.
- **KEEP WORK AREA CLEAN.** Cluttered areas and benches invite accidents.
- **DO NOT USE THE MACHINE IN A DANGEROUS ENVIRONMENT.** The use of power tools in damp or wet locations or in rain can cause shock or electrocution. Keep your work area well-lit to avoid tripping or placing arms, hands, and fingers in danger.
- **KEEP CHILDREN AWAY.** All visitors should be kept at a safe distance from work area. Your shop is a potentially dangerous environment.
- **MAKE WORKSHOP CHILDPROOF** with padlocks, master switches, or by removing starter keys. The unauthorized start-up of a machine by a child or visitor may result in injury.
- **DON'T FORCE TOOL.** It will do the job better and be safer at the rate for which it was designed.
- **USE RIGHT TOOL.** Don't force tool or attachment to do a job for which it was not designed. Using the incorrect tool or attachment may result in personal injury.
- **WEAR PROPER APPAREL.** Do not wear loose clothing, gloves, neckties, rings, bracelets, or other jewelry which may get caught in moving parts. Non-slip footwear is recommended. Wear protective hair covering to contain long hair.
- **ALWAYS USE SAFETY GLASSES.** Everyday eyeglasses are NOT safety glasses. Also use face or dust mask if cutting operation is dusty. **ALWAYS WEAR CERTIFIED SAFETY EQUIPMENT:**
 - ANSI Z87.1 eye protection (CAN/CSA Z94.3).
 - ANSI S12.6 (S3.19) hearing protection.
 - NIOSH/OSHA/MSHA respiratory protection.
- **SECURE THE WORKPIECE.** Use clamps or a vise to hold the workpiece on the table and against the fence or when your hand will be dangerously close to the blade within 6" (152 mm). It is safer than using your hand and it frees both hands to operate tool.
- **DON'T OVERREACH.** Keep proper footing and balance at all times. Loss of balance may cause personal injury.
- **MAINTAIN TOOLS WITH CARE.** Keep tools sharp and clean for best and safest performance. Follow instructions for lubricating and changing accessories. Poorly maintained tools and machines can further damage the tool or machine and/or cause injury.
- **TURN THE MACHINE "OFF", AND DISCONNECT THE MACHINE FROM THE POWER SOURCE** before installing or removing accessories, before adjusting or changing set-ups, when making repairs or changing locations. An accidental start-up can cause injury. Do not touch the plug's metal prongs when unplugging or plugging in the cord.
- **REDUCE THE RISK OF UNINTENTIONAL STARTING.** Make sure that the switch is in the "OFF" position before plugging in the power cord.
- **USE PROPER EXTENSION CORD.** Make sure your extension cord is in good condition. When using an extension cord, be sure to use one heavy enough to carry the current your product will draw. An undersized cord will cause a drop in line voltage resulting in loss of power and overheating. The following table shows the correct size to use depending on cord length and nameplate ampere rating. If in doubt, use the next heavier gauge. The smaller the gauge number, the heavier the cord.

Minimum Gauge for Cord Sets						
Ampere Rating		Volts	Total Length of Cord in Feet (meters)			
		120V	25 (7.6)	50 (15.2)	100 (30.5)	150 (45.7)
		240V	50 (15.2)	100 (30.5)	200 (61.0)	300 (91.4)
More Than	Not More Than	AWG				
0	6		18	16	16	14
6	10		18	16	14	12
10	12		16	16	14	12
12	16		14	12	Not Recommended	

- **CHECK FOR DAMAGED PARTS.** Before further use of the tool, a guard or other part that is damaged should be carefully checked to determine that it will operate properly and perform its intended function—check for alignment of moving parts, binding of moving parts, breakage of parts, mounting and any other conditions that may affect its operation. A guard or other part that is damaged should be properly repaired or replaced. Do not use tool if switch does not turn it on and off.
- **USE RECOMMENDED ACCESSORIES.** Use only accessories that are recommended by the manufacturer for your model. Accessories that may be suitable for one tool may be hazardous when used on another tool. Consult the instruction manual for recommended accessories. The use of improper accessories may cause risk of injury to persons.
- **NEVER STAND ON TOOL.** Serious injury could occur if the tool is tipped or if the cutting tool is unintentionally contacted.
- **NEVER LEAVE TOOL RUNNING UNATTENDED. TURN POWER OFF.** Don't leave tool until it comes to a complete stop. Serious injury can result.
- **DO NOT OPERATE ELECTRIC TOOLS NEAR FLAMMABLE LIQUIDS OR IN GASEOUS OR EXPLOSIVE ATMOSPHERES.** Motors in these tools may spark and ignite fumes.
- **STAY ALERT, WATCH WHAT YOU ARE DOING, AND USE COMMON SENSE. DO NOT USE THE MACHINE WHEN YOU ARE TIRED OR UNDER THE INFLUENCE OF DRUGS OR ALCOHOL.** A moment of inattention while operating power tools may result in injury.

Additional Safety Rules For Miter Saws

⚠WARNING: Do not allow familiarity (gained from frequent use of your saw) to replace safety rules. Always remember that a careless fraction of a second is sufficient to inflict severe injury.

- **DO NOT OPERATE THIS MACHINE** until it is completely assembled and installed according to the instructions. A machine incorrectly assembled can cause serious injury.
- **OBTAIN ADVICE** from your supervisor, instructor, or another qualified person if you are not thoroughly familiar with the operation of this machine. Knowledge is safety.
- **STABILITY.** Make sure the miter saw is placed on a secure supporting surface and does not slip or move during use.
- **FOLLOW ALL WIRING CODES** and recommended electrical connections to prevent shock or electrocution. Protect electric supply line with at least a 15 ampere time-delay fuse or a circuit breaker.
- **MAKE CERTAIN** the blade rotates in the correct direction. The teeth on the blade should point in the direction of rotation as marked on the saw.
- **TIGHTEN ALL CLAMP HANDLES,** knobs and levers prior to operation. Loose clamps can cause parts or the workpiece to be thrown at high speeds.
- **BE SURE** all blade and blade clamps are clean, recessed sides of blade clamps are against blade and arbor screw is tightened securely. Loose or improper blade clamping may result in damage to the saw and possible personal injury.

- **ALWAYS USE A SHARP BLADE.** Check the blade to see if it runs true and is free from vibration. A dull or a vibrating blade can cause damage to the machine and/or serious injury.
- **DO NOT OPERATE ON ANYTHING OTHER THAN THE DESIGNATED VOLTAGE** for the saw. Overheating, damage to the tool and personal injury may occur.
- **DO NOT WEDGE ANYTHING AGAINST THE FAN** to hold the motor shaft. Damage to tool and possible personal injury may occur.
- **DO NOT FORCE CUTTING ACTION.** Stalling or partial stalling of motor can cause damage to the machine or blade and/or serious injury.
- **ALLOW THE MOTOR TO COME TO FULL SPEED** prior to starting cut. Starting the cut too soon may cause damage to the machine or blade and/or serious injury.
- **NEVER CUT FERROUS METALS** (those with any iron or steel content) or masonry. Either of these can cause the carbide tips to fly off the blade at high speeds causing serious injury.
- **DO NOT USE ABRASIVE WHEELS.** The excessive heat and abrasive particles generated by them may damage the saw and cause personal injury.
- **NEVER HAVE ANY PART OF YOUR BODY IN LINE WITH THE PATH OF THE SAW BLADE.** Personal injury will occur.
- **NEVER APPLY BLADE LUBRICANT TO A RUNNING BLADE.** Applying lubricant could cause your hand to move into the blade resulting in serious injury.
- **DO NOT** place either hand in the blade area when the saw is connected to the power source. Inadvertent blade activation may result in serious injury.
- **DO NOT PERFORM FREEHAND OPERATIONS** (workpiece not supported by table and fence). Hold the work firmly against the fence and table. Freehand operations on a miter saw could cause the workpiece to be thrown at high speeds, causing serious injury.
- **NEVER REACH AROUND OR BEHIND THE SAW BLADE.** A blade can cause serious injury.
- **DO NOT REACH UNDERNEATH THE SAW** unless it is unplugged and turned off. Contact with saw blade may cause personal injury.
- **SECURE THE MACHINE TO A STABLE SUPPORTING SURFACE.** Vibration can possibly cause the machine to slide, walk, or tip over, causing serious injury.
- **USE ONLY CROSSCUT SAW BLADES** recommended for miter saws. For best results, do not use carbide tipped blades with hook angles in excess of 7 degrees. Do not use blades with deep gullets. These can deflect and contact the guard, and can cause damage to the machine and/or serious injury.
- **USE ONLY BLADES OF THE CORRECT SIZE AND TYPE** specified for this tool to prevent damage to the machine and/or serious injury.
- **INSPECT BLADE FOR CRACKS** or other damage prior to operation. A cracked or damaged blade can come apart and pieces can be thrown at high speeds, causing serious injury. Replace cracked or damaged blades immediately.
- **CLEAN THE BLADE AND BLADE CLAMPS** prior to operation. Cleaning the blade and blade clamps allows you to check for any damage to the blade or blade clamps. A cracked or damaged blade or blade clamp can come apart and pieces can be thrown at high speeds, causing serious injury.
- **DO NOT** use lubricants or cleaners (particularly spray or aerosol) in the vicinity of the plastic guard. The polycarbonate material used in the guard is subject to attack by certain chemicals.
- **ALWAYS USE THE KERF PLATE AND REPLACE THIS PLATE WHEN DAMAGED.** Small chip accumulation under the saw may interfere with the saw blade or may cause instability of workpiece when cutting.
- **USE ONLY BLADE CLAMPS SPECIFIED FOR THIS TOOL** to prevent damage to the machine and/or serious injury.

- **CLEAN THE MOTOR AIR SLOTS** of chips and sawdust. Clogged motor air slots can cause the machine to overheat, damaging the machine and possibly causing a short which could cause serious injury.
- **KEEP ARMS, HANDS, AND FINGERS AWAY FROM THE BLADE** to prevent severe cuts. Clamp all workpieces that would cause your hand to be within 6" (152 mm) of the saw blade.
- **NEVER LOCK THE SWITCH IN THE "ON" POSITION.** Severe personal injury may result.
- **TURN OFF THE MACHINE** and allow the blade to come to a complete stop before raising the arm and prior to cleaning the blade area, removing debris in the path of the blade, before servicing or adjusting tool. A moving blade can cause serious injury.
- **PROPERLY SUPPORT LONG OR WIDE WORKPIECES.** Loss of control of the workpiece can cause injury.
- **NEVER CROSS ARMS IN FRONT OF BLADE** while using tool. Always make a dry run (unpowered) before making a finish cut so that you can check the path of the blade or severe personal injury may result.
- **ADDITIONAL INFORMATION** regarding the safe and proper operation of power tools (i.e., a safety video) is available from the Power Tool Institute, 1300 Sumner Avenue, Cleveland, OH 44115-2851 (www.powertoolinstitute.com). Information is also available from the National Safety Council, 1121 Spring Lake Drive, Itasca, IL 60143-3201. Please refer to the American National Standards Institute ANSI 01.1 Safety Requirements for Woodworking Machines and the U.S. Department of Labor OSHA 1910.213 Regulations.

⚠WARNING: Do not connect unit to electrical power source until complete instructions are read and understood.

⚠WARNING: Always wear proper personal hearing protection that conforms to ANSI S12.6 (S3.19) during use. Under some conditions and duration of use, noise from this product may contribute to hearing loss.

⚠WARNING: NEVER MAKE ANY CUT UNLESS THE MATERIAL IS SECURED ON THE TABLE AND AGAINST THE FENCE.

⚠WARNING: Some dust created by power sanding, sawing, grinding, drilling, and other construction activities contains chemicals known to the State of California to cause cancer, birth defects or other reproductive harm. Some examples of these chemicals are:

- lead from lead-based paints,
- crystalline silica from bricks and cement and other masonry products, and
- arsenic and chromium from chemically-treated lumber.

Your risk from these exposures varies, depending on how often you do this type of work. To reduce your exposure to these chemicals: work in a well ventilated area, and work with approved safety equipment, such as those dust masks that are specially designed to filter out microscopic particles.

- **Avoid prolonged contact with dust from power sanding, sawing, grinding, drilling, and other construction activities. Wear protective clothing and wash exposed areas with soap and water. Allowing dust to get into your mouth, eyes, or lay on the skin may promote absorption of harmful chemicals.**

⚠WARNING: Use of this tool can generate and/or disperse dust, which may cause serious and permanent respiratory or other injury. Always use NIOSH/OSHA approved respiratory protection appropriate for the dust exposure. Direct particles away from face and body.

For your convenience and safety, the following warning labels are on your miter saw.

ON MOTOR HOUSING:

⚠WARNING: FOR YOUR OWN SAFETY, READ INSTRUCTION MANUAL BEFORE OPERATING MITER SAW.

WHEN SERVICING, USE ONLY IDENTICAL REPLACEMENT PARTS.

**DO NOT EXPOSE TO RAIN OR USE IN DAMP LOCATIONS.
ALWAYS USE PROPER EYE AND RESPIRATORY PROTECTION.**

ON MOVING FENCES:

ALWAYS ADJUST FENCE PROPERLY BEFORE USE. CLAMP SMALL PIECES BEFORE CUTTING. SEE MANUAL.

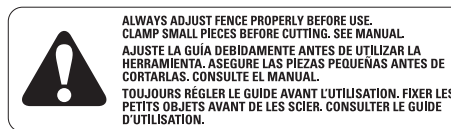

ON GUARD:

DANGER—KEEP AWAY FROM BLADE.

ON UPPER GUARD:

PROPERLY SECURE BRACKET WITH BOTH SCREWS BEFORE USE.



ON TABLE: (2 PLACES)

⚠WARNING: FOR YOUR OWN SAFETY, READ INSTRUCTION MANUAL BEFORE OPERATING MITER SAW. KEEP HANDS OUT OF PATH OF SAW BLADE. DO NOT OPERATE SAW WITHOUT GUARDS IN PLACE. CHECK LOWER GUARD FOR PROPER CLOSING BEFORE EACH USE. ALWAYS TIGHTEN ADJUSTMENT KNOBS BEFORE USE. DO NOT PERFORM ANY OPERATION FREEHAND. NEVER REACH IN BACK OF SAW BLADE. NEVER CROSS ARMS IN FRONT OF BLADE. TURN OFF TOOL AND WAIT FOR SAW BLADE TO STOP BEFORE MOVING WORKPIECE, CHANGING SETTINGS OR MOVING HANDS. DISCONNECT POWER BEFORE CHANGING BLADE OR SERVICING. TO REDUCE THE RISK OF INJURY, RETURN CARRIAGE TO THE FULL REAR POSITION AFTER EACH CROSSCUT OPERATION. THINK! YOU CAN PREVENT ACCIDENTS.



ON BASE: (2 PLACES)



Electrical Connection

Be sure your power supply agrees with the nameplate marking. 120 volts, AC means that your saw will operate on alternating current. The switch is susceptible to failure if direct current is used. A voltage decrease of 10 percent or more will cause a loss of power and overheating. All DEWALT tools are factory tested. If this tool does not operate, check the power supply.

Accessories

⚠WARNING: Since accessories, other than those offered by DEWALT, have not been tested with this product, use of such accessories with this tool could be hazardous. To reduce the risk of injury, only DEWALT recommended accessories should be used with this product.

Recommended accessories for use with your tool are available for purchase from your local dealer or authorized service center. If you need assistance in locating any accessory for your tool, please contact DEWALT Industrial Tool Co., 701 East Joppa Road, Towson, MD 21286, call 1-800-4-DEWALT (1-800-433-9258) or visit our website: www.dewalt.com.

Optional Accessories (Fig. 1)

The following accessories, designed for your saw, may be helpful. In some cases, other locally obtained work supports, length stops, clamps, etc., may be more appropriate. Use care in selecting and using accessories.

FIG. 1

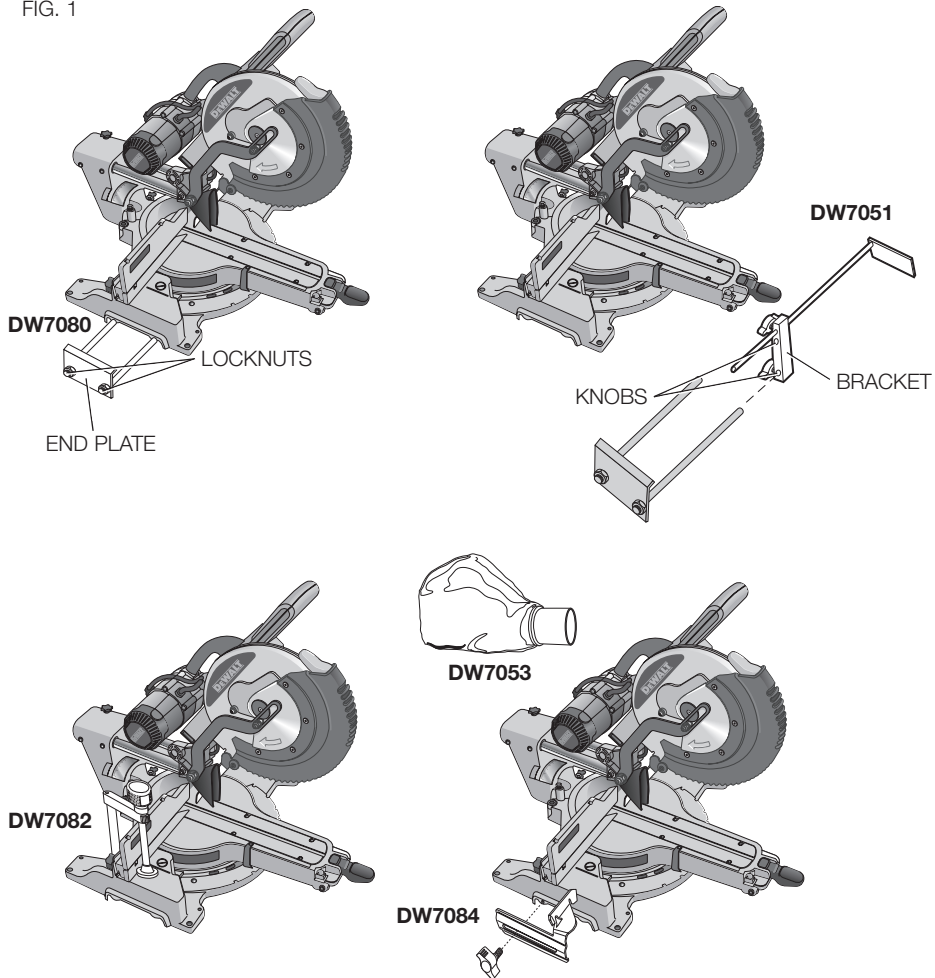

Extension Work Support: DW7080

Used to support long overhanging workpieces, the work support is user assembled. Your saw base is designed to accept two work supports, one on each side.

Adjustable Length Stop: DW7051

Requires the use of one Extension Work Support (DW7080) (refer to Figure 1). It is used to make repetitive cuts of the same length from 0 to 42" (107 cm).

Clamp: DW7082 (similar model included)

Used for firmly clamping workpiece to the saw table for precision cutting.

Dust Bag: DW7053 (included with some models)

Equipped with a zipper for easy emptying, the dust bag will capture the majority of the sawdust produced.

Crown Molding Fence: DW7084

Used for precision cutting of crown molding.

SAW BLADES: ALWAYS USE 12" (305 mm) SAW BLADES WITH EITHER 1" (25.4 mm) OR 5/8" (15.88 mm) ARBOR HOLES. SPEED RATING MUST BE AT LEAST 4800 RPM. Never

use a smaller diameter blade. It will not be guarded properly. Use crosscut blades only! Do not use blades designed for ripping, combination blades or blades with hook angles in excess of 7°.

BLADE DESCRIPTIONS		
APPLICATION	DIAMETER	TEETH
Construction Saw Blades (<i>thin kerf with anti-stick rim</i>)		
General Purpose	12" (305 mm)	40
Fine Crosscuts	12" (305 mm)	60
Woodworking Saw Blades (<i>provide smooth, clean cuts</i>)		
Fine crosscuts	12" (305 mm)	80
Non-ferrous metals	12" (305 mm)	96

NOTE: For cutting non-ferrous metals, use only saw blades with TCG (Triple Chip Grind) teeth designed for this purpose.

Unpacking Your Saw

Check the contents of your miter saw carton to make sure that you have received all parts. In addition to this instruction manual, the carton should contain:

- 1 DWS780 miter saw
- 1 DEWALT 12" (305 mm) diameter saw blade
- In bag:
 - 1 Blade wrench
 - 1 DW7053 dustbag
 - 1 Material clamp

Specifications

CAPACITY OF CUT

50° miter left, 60° miter right,
49° bevel left and right

ANGLE	MAXIMUM CAPACITY OF CUT		RESULT	
	Height	Width	Height	Width
0° miter	4.4" (112 mm)	9.1" (231 mm)	13.75" (349 mm)	3.0" (76 mm)
	13.75" (349 mm)	3.0" (76 mm)	4.4" (112 mm)	5.8" (147 mm)
45° miter	4.4" (112 mm)	11.4" (290 mm)	9.6" (244 mm)	3.0" (76 mm)
	9.6" (244 mm)	3.0" (76 mm)	3.1" (79 mm)	11.4" (290 mm)
45° bevel – left	3.1" (79 mm)	11.4" (290 mm)	13.75" (349 mm)	1.7" (43 mm)
	13.75" (349 mm)	1.7" (43 mm)	2.2" (56 mm)	11.4" (290 mm)
45° bevel – right	2.2" (56 mm)	11.4" (290 mm)	13.75" (349 mm)	1.1" (28 mm)
	13.75" (349 mm)	1.1" (28 mm)		

Your saw is capable of cutting baseboard moldings held vertically 0.8" (20 mm) thick by 6.75" (171 mm) tall on a 45° right or left miter, when using the slide lock lever (Fig. 7).

NOTE: Your saw is capable of cutting the following once a special setup procedure is followed. Refer to **Special Cuts**.

0° miter	Height 1.5" (38 mm)	Width 16.1" (409 mm)
45° miter	Height 1.5" (38 mm)	Width 11.7" (297 mm)

Familiarization

Your miter saw is fully assembled in the carton. Open the box and lift the saw out by the convenient lifting handle, as shown in Figure 2.

Place the saw on a smooth, flat surface such as a workbench or strong table.

Examine Figure 4 to become familiar with the saw and its various parts. The section on adjustments will refer to these terms and you must know what and where the parts are.

CAUTION: Pinch hazard. To reduce the risk of injury, keep thumb underneath the operating handle when pulling the handle down. The lower guard will move up as the operating handle is pulled down, which could cause pinching. The operating handle is placed close to the guard for special cuts.

Press down lightly on the operating handle and pull out the lock down pin. Gently release the downward pressure and hold the operating handle, allowing it to rise to its full height. Use the lock down pin when carrying the saw from one place to another. Always use the lifting handle to transport the saw, or use the hand indentations shown in Figure 4.

Bench Mounting

Holes are provided in all 4 feet to facilitate bench mounting, as shown in Figure 4. (Two different-sized holes are provided to accommodate different sizes of screws. Use either hole, it is not necessary to use both.) Always mount your saw firmly to a stable surface to prevent movement. To enhance the tool's portability, it can be mounted to a piece of 1/2" (12.7 mm) or thicker plywood which can then be clamped to your work support or moved to other job sites and reclamped.

NOTE: If you elect to mount your saw to a piece of plywood, make sure that the mounting screws don't protrude from the bottom of the wood. The plywood must sit flush on the work support. When clamping the saw to any work surface, clamp only on the clamping bosses where the mounting screw holes are located. Clamping at any other point will interfere with the proper operation of the saw.

CAUTION: To prevent binding and inaccuracy, be sure the mounting surface is not warped or otherwise uneven. If the saw rocks on the surface, place a thin piece of material under one saw foot until the saw sits firmly on the mounting surface.

IMPORTANT SAFETY INSTRUCTIONS

Changing or Installing a New Saw Blade (Fig. 3)

WARNING: To reduce the risk of serious personal injury, turn off the tool and disconnect it from the power source before attempting to move it, change accessories or make any adjustments.

CAUTION:

- Never depress the spindle lock button while the blade is under power or coasting.
- Do not cut ferrous metal (containing iron or steel) or masonry or fiber cement product with this miter saw.

Removing the Blade (Fig. 3)

1. Unplug the saw.
2. Raise the arm to the upper position and raise the lower guard (A) as far as possible.

FIG. 2

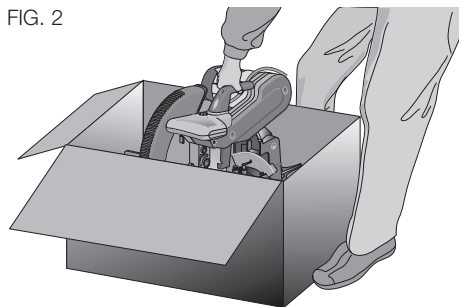

3. Loosen, but do not remove guard bracket screw (B) until the bracket can be raised far enough to access the blade screw (E). Lower guard will remain raised due to the position of the guard bracket screw.
4. Depress the spindle lock button (C) while carefully rotating the saw blade by hand until the lock engages.
5. Keeping the button depressed, use the other hand and the wrench provided (D) to loosen the blade screw. (Turn clockwise, left-hand threads.)
6. Remove the blade screw (E), outer clamp washer (F), blade (G) and blade adapter (H), if used. The inner clamp washer (I) may be left on the spindle.

NOTE: For blades with a blade hole of 5/8" (15.88 mm), the 1" (25.4 mm) blade adapter (H) is not used.

Installing a Blade (Fig. 3)

1. Unplug the saw.
2. With the arm raised, the lower guard held open and the guard bracket raised, place the blade on the spindle, onto the blade adapter (if using a blade with a 1" [25.4 mm] diameter blade hole) and against the inner blade clamp with the teeth at the bottom of the blade pointing toward the back of the saw.
3. Assemble the outer clamp washer onto the spindle.
4. Install the blade screw and, engaging the spindle lock, tighten the screw firmly with wrench provided (turn counterclockwise, left-hand threads).

NOTE: When using blades with a 5/8" (15.88 mm) diameter blade hole, the blade adapter will not be used and should be stored in a safe place for future use. The separate blade adapter is not available on all models.

5. Return the guard bracket to its original position and firmly tighten the guard bracket screw to hold bracket in place.

WARNING:

- The guard bracket must be returned to its original position and the guard bracket screw tightened before activating the saw.
- Failure to do so may allow the guard to contact the spinning saw blade resulting in damage to the saw and severe personal injury.

Transporting the Saw

WARNING: To reduce the risk of serious personal injury, turn off the tool and disconnect it from the power source before attempting to move it, change accessories or make any adjustments.

WARNING: To reduce the risk of serious personal injury, ALWAYS lock the rail lock knob, miter lock handle, bevel lock handle, lock down pin and fence adjustment knobs before transporting saw.

In order to conveniently carry the miter saw from place to place, a lifting handle has been included on the top of the saw arm and hand indentations in the base, as shown in Figure 4.

FEATURES AND CONTROLS

WARNING: To reduce the risk of serious personal injury, turn off the tool and disconnect it from the power source before attempting to move it, change accessories or make any adjustments.

MITER CONTROL (FIG. 5)

The miter lock handle and miter latch button allow you to miter your saw to 60° right and 50° left. To miter the saw, lift the miter lock handle, push the miter latch button and set the miter angle desired on the miter scale. Push down on the miter lock handle to lock the miter angle.

FIG. 3

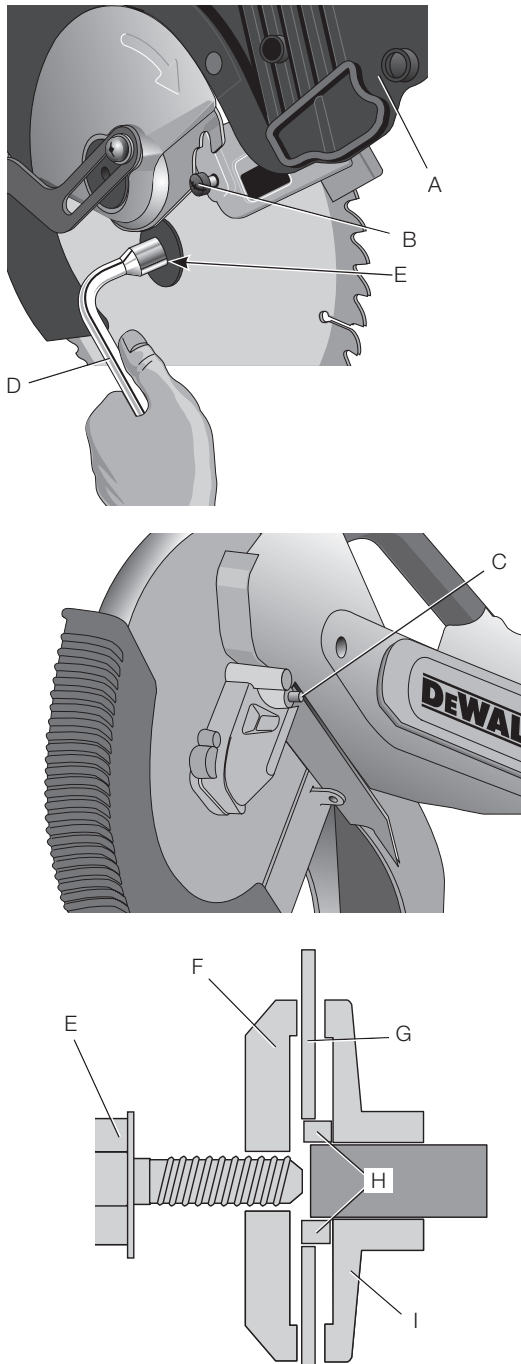
**TRIGGER SWITCH (FIG. 4)**

The trigger switch turns your saw on and off. A hole is provided in the trigger for insertion of a padlock to secure the saw.

MITER LATCH OVERRIDE (FIG. 5)

The miter latch override allows your saw to override the common stop angles. To override the common stop angles, push the miter latch button and flip the miter latch override lever to the vertical position.

BEVEL LOCK KNOB (FIG. 4)

The bevel lock allows you to bevel the saw 49° left or right. To adjust the bevel setting, turn the knob counterclockwise. The saw head bevels easily to the left or to the right once the 0° bevel override knob is pulled. To tighten, turn the bevel lock knob clockwise.

0° BEVEL OVERRIDE (FIG. 4)

The bevel stop override allows you to bevel the saw to the right past the 0° mark.

When engaged, the saw will automatically stop at 0° when brought up from the left. To temporarily move past 0° to the right, pull the bevel lock knob. Once the knob is released, the override will be reengaged. The bevel lock knob can be locked out by twisting the knob 180°.

When at 0°, the override locks in place. To operate the override, bevel the saw slightly to the left.

45° BEVEL STOP OVERRIDE (FIG. 6)

There are two bevel stop override levers, one on each side of the saw. To bevel the saw, left or right, past 45°, push the 45° bevel override lever rearward. When in the rearward position, the saw can bevel past these stops. When the 45° stops are needed, pull the 45° bevel override lever forward.

CROWN BEVEL PAWLS (FIG. 6)

When cutting crown molding laying flat, your saw is equipped to accurately and rapidly set a crown stop, left or right (refer to *Instructions for Cutting Crown Molding Laying Flat and Using the Compound Features*). The crown bevel pawl can be rotated to contact the crown adjustment screw. The saw is factory set to be used for typical crown in North America (52/38), but can be reversed to cut non-typical (45/45) crown. To reverse the crown bevel pawl, remove the retaining screw, the 22.5° bevel pawl and the 33.9° crown bevel pawl. Flip the crown bevel pawl so the 30° text is facing up. Reattach the screw to secure the 22.5° bevel pawl and the crown bevel pawl. The accuracy setting will not be affected.

22.5° BEVEL PAWLS (FIG. 6)

Your saw is equipped to rapidly and accurately set a 22.5° bevel, left or right. The 22.5° bevel pawl can be rotated to contact the crown adjustment screw.

RAIL LOCK KNOB (FIG. 4)

The rail lock knob allows you to lock the saw head firmly to keep it from sliding on the rails. This is necessary when making certain cuts or when transporting the saw.

DEPTH STOP (FIG. 4)

The depth stop allows the depth of cut of the blade to be limited. The stop is useful for applications such as grooving and tall vertical cuts. Rotate the depth stop forward and adjust the depth adjustment screw to set the desired depth of cut. To secure the adjustment, tighten the wing nut. Rotating the depth stop to the rear of the saw will bypass the depth stop feature. If the depth adjustment screw is too tight to loosen by hand, the provided blade wrench can be used to loosen the screw.

LOCK DOWN PIN (FIG. 4)

⚠WARNING: The lock down pin should be used *ONLY* when carrying or storing the saw. *NEVER* use the lock down pin for any cutting operation.

To lock the saw head in the down position, push the saw head down, push the lock down pin in and release the saw head. This will hold the saw head safely down for moving the saw from place to place. To release, press the saw head down and pull the pin out.

SLIDE LOCK LEVER (FIG. 7)

The slide lock lever places the saw in a position to maximize cutting of base molding when cut vertically as shown in Figure 16.

AUTOMATIC ELECTRIC BRAKE

Your saw is equipped with an automatic electric blade brake which stops the saw blade within 5 seconds of trigger release. This is not adjustable.

On occasion, there may be a delay after trigger release to brake engagement. On rare occasions, the brake may not engage at all and the blade will coast to a stop.

If a delay or “skipping” occurs, turn the saw on and off 4 or 5 times. If the condition persists, have the tool serviced by an authorized DEWALT service center.

Always be sure the blade has stopped before removing it from the kerf. The brake is not a substitute for guards or for ensuring your own safety by giving the saw your complete attention.

OPERATION

⚠WARNING: To reduce the risk of serious personal injury, turn off the tool and disconnect it from the power source before attempting to move it, change accessories or make any adjustments.

⚠WARNING: Always use eye protection. All users and bystanders must wear eye protection that conforms to ANSI Z87.1 (CAN/CSA Z94.3).

Plug the saw into any household 60 Hz power source. Refer to the nameplate for voltage. Be sure the cord will not interfere with your work.

FIG. 4

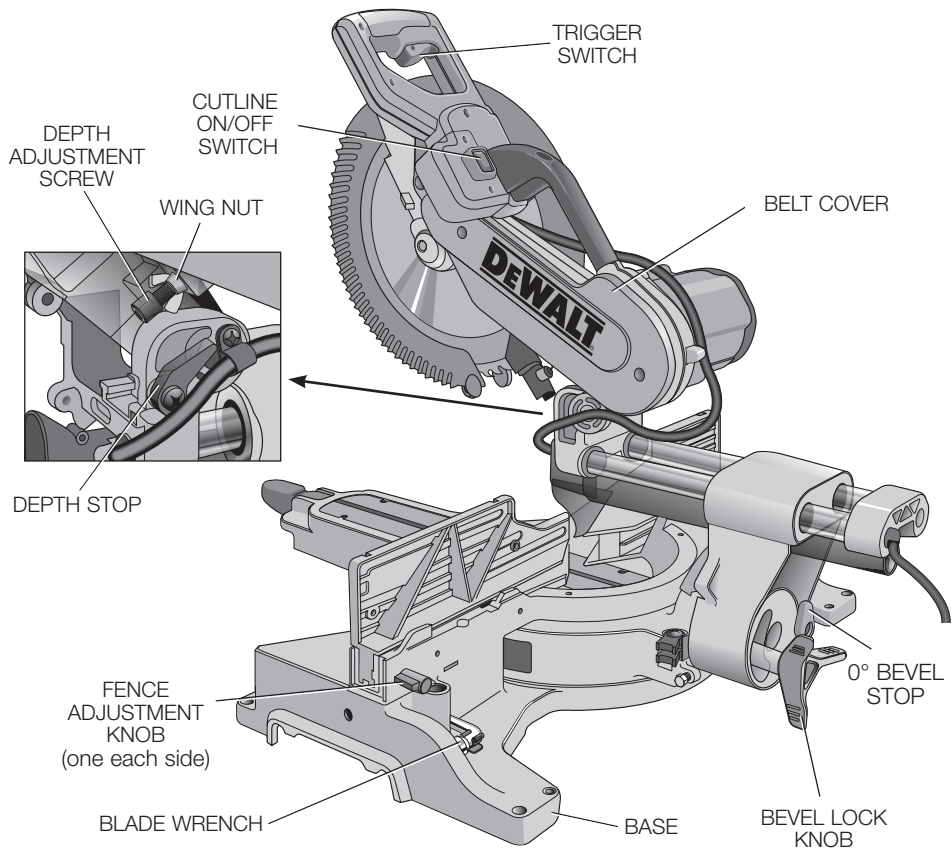
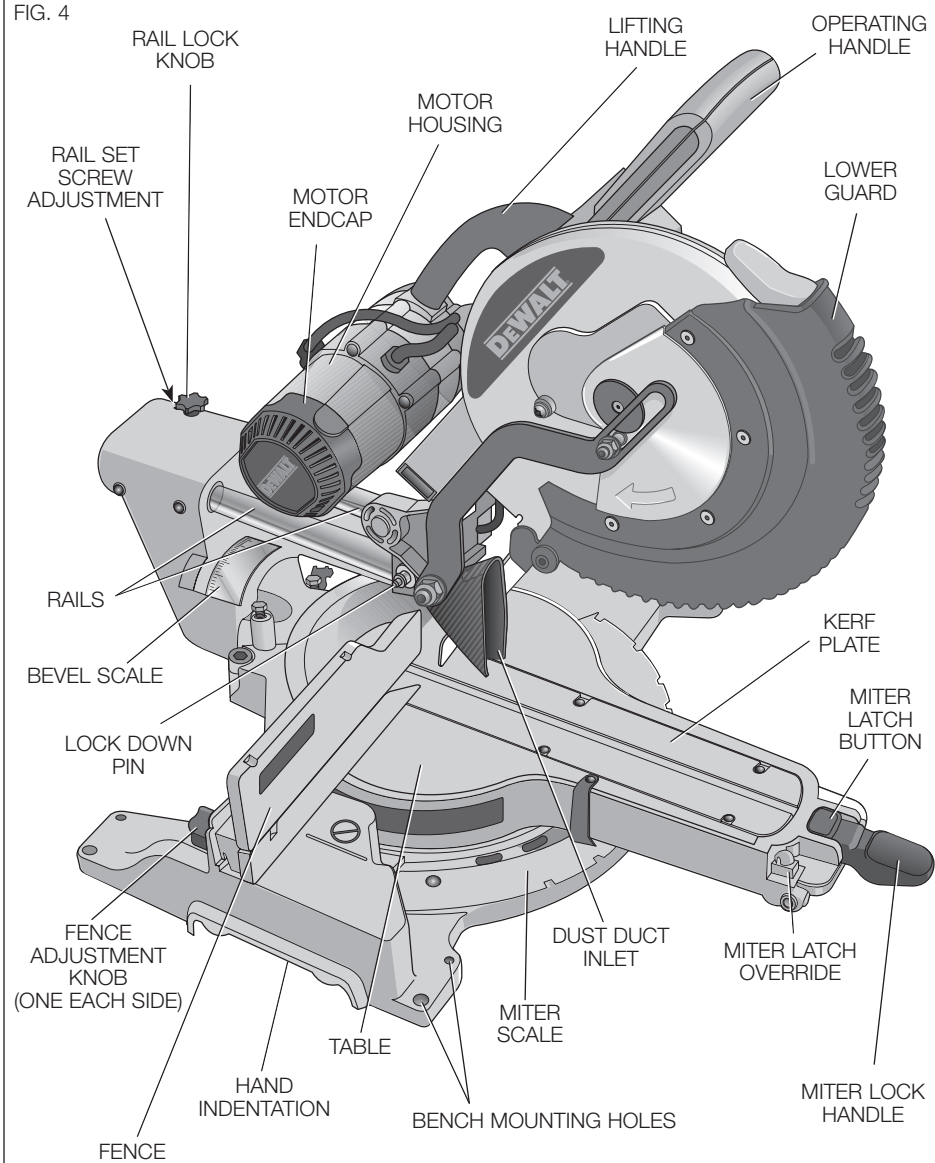

FIG. 5

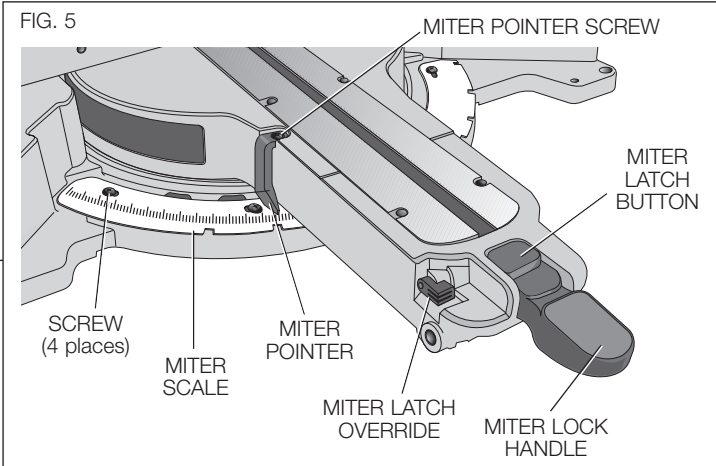

FIG. 6

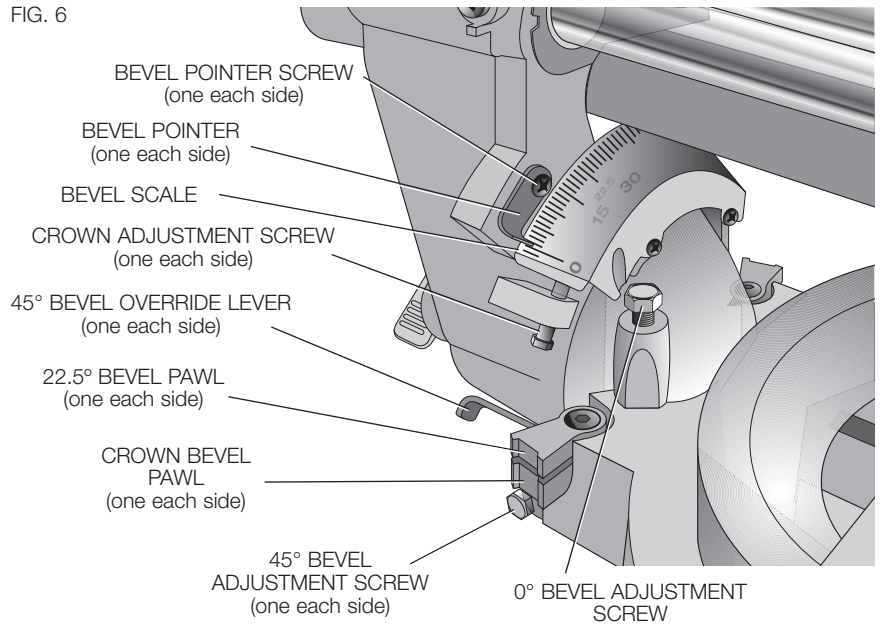

FIG. 7

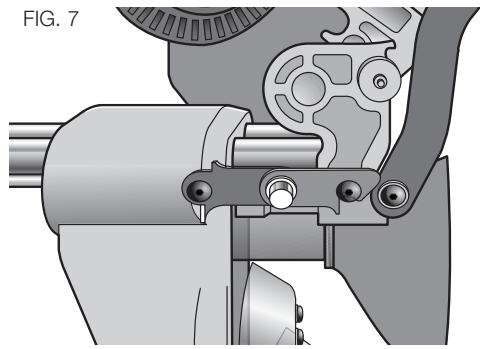
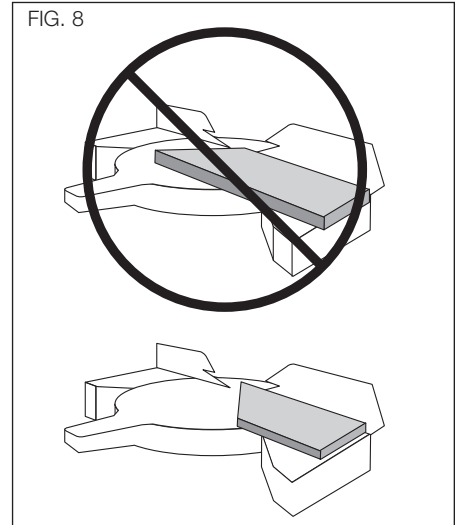

FIG. 8



Trigger Switch (Fig. 4)

To turn the saw on, depress the trigger switch. To turn the tool off, release the switch. Allow the blade to spin up to full operating speed before making the cut. Release the trigger switch and allow the brake to stop the blade before raising the saw head. There is no provision for locking the switch on, but a hole is provided in the trigger for insertion of a padlock to lock the saw off.

Use of CUTLINE LED Worklight System (Fig. 4)

NOTE: The miter saw must be connected to a power source. The CUTLINE LED Worklight System is equipped with an ON/OFF switch (Fig. 4). The CUTLINE LED Worklight System is independent of the miter saw's trigger switch. The light does not need to be on in order to operate the saw.

To cut through an existing pencil line on a piece of wood, turn on the CUTLINE system, then pull down on the operating handle to bring the saw blade close to the wood. The shadow of the blade will appear on the wood. This shadow line represents the material that the blade will remove when performing a cut. To correctly locate your cut to the pencil line, align the pencil line with the edge of the blade's shadow. Keep in mind that you may have to adjust the miter or bevel angles in order to match the pencil line exactly.

Cutting With Your Saw

If the slide feature is not used, ensure the saw head is pushed back as far as possible and the rail lock knob is tightened. This will prevent the saw from sliding along its rails as the workpiece is engaged.

NOTE: Although this saw will cut wood and many non-ferrous materials, we will limit our detailed discussion to the cutting of wood only. The same guidelines apply to the other materials. **DO NOT CUT FERROUS (IRON AND STEEL) MATERIALS OR MASONRY WITH THIS SAW.** Do not use any abrasive blades.

NOTE: Refer to **Guard Actuation and Visibility** in the **Adjustments** section for important information about the lower guard before cutting.

CROSSCUTS

A crosscut is made by cutting wood across the grain at any angle. A straight crosscut is made with the miter arm at the zero degree position. Set and lock the miter arm at zero, hold the wood firmly on the table and against the fence. With the rail lock knob tightened, turn on the saw by squeezing the trigger switch shown in Figure 4.

When the saw comes up to speed (about 1 second) lower the arm smoothly and slowly to cut through the wood. Let the blade come to a full stop before raising arm.

When cutting anything larger than a 2 x 8 (51 x 203 mm [2 x 6 (51 x 152) at 45° miter]) use an out-down-back motion with the rail lock knob loosened. Pull the saw out, toward you, lower the saw head down toward the workpiece, and slowly push the saw back to complete the cut. Do not allow the saw to contact the top of the workpiece while pulling out. The saw may run toward you, possibly causing personal injury or damage to the workpiece.

Cutting of multiple pieces is not recommended but can be done safely by ensuring that each piece is held firmly against the table and fence.

NOTE: To provide greater crosscut capacity with reduced stroke, the blade on the DWS780 extends deeper into the table. As a result, a greater lifting force on the workpiece may be experienced during the cut.

CAUTION: Always use a work clamp to maintain control and reduce the risk of workpiece damage and personal injury, if your hands are required to be within 6" (152 mm) of the blade during the cut.

NOTE: The rail lock knob shown in Figure 4 must be loose to allow the saw to slide along its rails.

Miter crosscuts are made with the miter arm at some angle other than zero. This angle is often 45° for making corners, but can be set anywhere from zero to 50° left or 60° right. Make the cut as described above.

When performing a miter cut on workpieces wider than a 2 x 6 that are shorter in length, always place the longer side against the fence (Fig. 8).

To cut through an existing pencil line on a piece of wood, match the angle as close as possible. Cut the wood a little too long and measure from the pencil line to the cut edge to determine which direction to adjust the miter angle and recut. This will take some practice, but it is a commonly used technique.

BEVEL CUTS

A bevel cut is a crosscut made with the saw blade leaning at an angle to the wood. In order to set the bevel, loosen the bevel lock (Fig. 4), and move the saw to the left or right as desired. (It is necessary to move the fence to allow clearance.) Once the desired bevel angle has been set, tighten the bevel lock firmly. Refer to the **Features and Controls** section for detailed instructions on the bevel system.

Bevel angles can be set from 49° right to 49° left and can be cut with the miter arm set between 50° left or 60° right. At some extreme angles, the right or left side fence might have to be removed. To remove the left or right fence, unscrew the fence adjustment knob several turns and slide the fence out.

NOTE: Refer to **Fence Adjustment** in the **Adjustments** section for important information on adjusting the fences for certain bevel cuts.

QUALITY OF CUT

The smoothness of any cut depends on a number of variables. Things like material being cut, blade type, blade sharpness and rate of cut all contribute to the quality of the cut.

When smoothest cuts are desired for molding and other precision work, a sharp (60 tooth carbide) blade and a slower, even cutting rate will produce the desired results.

Ensure that the material does not move or creep while cutting; clamp it securely in place. Always let the blade come to a full stop before raising arm.

If small fibers of wood still split out at the rear of the workpiece, stick a piece of masking tape on the wood where the cut will be made. Saw through the tape and carefully remove tape when finished.

For varied cutting applications, refer to the list of recommended saw blades for your saw and select the one that best fits your needs. Refer to **Saw Blades** under **Optional Accessories**.

BODY AND HAND POSITION (FIG. 9A, 9B)

Proper positioning of your body and hands when operating the miter saw will make cutting easier, more accurate and safer. Never place hands near cutting area. Place hands no closer than 6" (152 mm) from the blade. Hold the workpiece tightly to the table and the fence when cutting. Keep hands in position until the trigger has been released and the blade has completely stopped. **ALWAYS MAKE DRY RUNS (UNPOWERED) BEFORE FINISH CUTS SO THAT YOU**

CAN CHECK THE PATH OF THE BLADE. DO NOT CROSS HANDS, AS SHOWN IN FIGURE 9B.

Keep both feet firmly on the floor and maintain proper balance. As you move the miter arm left and right, follow it and stand slightly to the side of the saw blade. Sight through the guard louvers when following a pencil line.

CLAMPING THE WORKPIECE

⚠WARNING: To reduce the risk of serious personal injury, turn off the tool and disconnect it from the power source before attempting to move it, change accessories or make any adjustments.

⚠WARNING: A workpiece that is clamped, balanced and secure before a cut may become unbalanced after a cut is completed. An unbalanced load may tip the saw or anything the saw is attached to, such as a table or workbench. When making a cut that may become unbalanced, properly support the workpiece and ensure the saw is firmly bolted to a stable surface. Personal injury may occur.

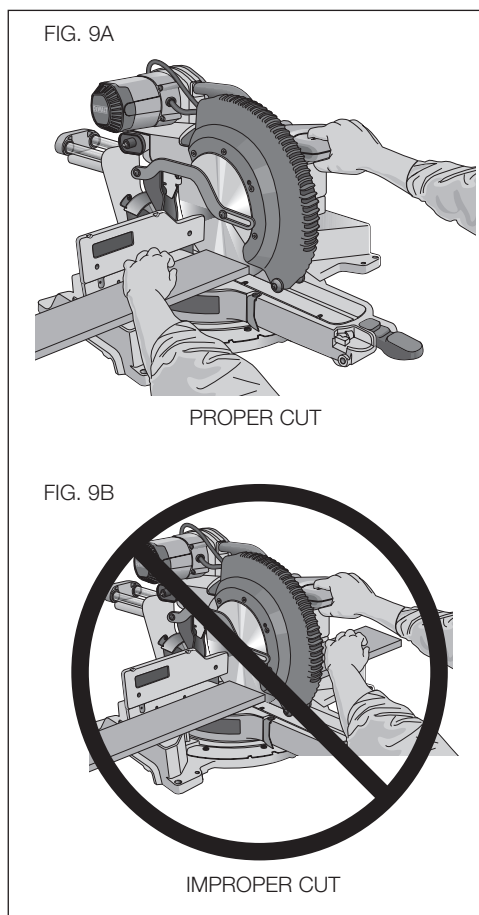

⚠WARNING: The clamp foot must remain clamped above the base of the saw whenever the clamp is used. Always clamp the workpiece to the base of the saw – not to any other part of the work area. Ensure the clamp foot is not clamped on the edge of the base of the saw.

⚠CAUTION: Always use a work clamp to maintain control and reduce the risk of workpiece damage and personal injury, if your hands are required to be within 6" of the blade during the cut.

If you cannot secure the workpiece on the table and against the fence by hand (irregular shape, etc.), or your hand would be less than 6" (152 mm) from the blade, a clamp or other fixture must be used.

Use the material clamp provided with your saw. To purchase the material clamp, contact your local retailer or DEWALT service center.

Other aids such as spring clamps, bar clamps or C-clamps may be appropriate for certain sizes and shapes of material. Use care in selecting and placing these clamps. Take time to make a dry run before making the cut. The left or right fence will slide from side to side to aid in clamping.

TO INSTALL CLAMP

1. Insert it into the hole behind the fence. The clamp should be facing toward the back of the miter saw. The groove on the clamp rod should be fully inserted into the base. Ensure this groove is fully inserted into the base of the miter saw. If the groove is visible, the clamp will not be secure.
2. Rotate the clamp 180° toward the front of the miter saw.
3. Loosen the knob to adjust the clamp up or down, then use the fine adjust knob to firmly clamp the workpiece.

NOTE: Place the clamp on the opposite side of the base when beveling. **ALWAYS MAKE DRY RUNS (UNPOWERED) BEFORE FINISH CUTS TO CHECK THE PATH OF THE BLADE. ENSURE THE CLAMP DOES NOT INTERFERE WITH THE ACTION OF THE SAW OR GUARDS.**

ADJUSTMENTS

⚠WARNING: To reduce the risk of serious personal injury, turn off the tool and disconnect it from the power source before attempting to move it, change accessories or make any adjustments.

Your miter saw is fully and accurately adjusted at the factory at the time of manufacture. If readjustment due to shipping and handling or any other reason is required, follow the instructions below to adjust your saw.

Once made, these adjustments should remain accurate. Take a little time now to follow these directions carefully to maintain the accuracy of which your saw is capable.

MITER SCALE ADJUSTMENT (FIG. 5, 10)

Unlock the miter lock handle and swing the miter arm until the miter latch button locks it at the 0° miter position. Do not lock the miter lock handle. Place a square against the saw's fence and blade, as shown. (Do not touch the tips of the blade teeth with the square. To do so will cause an inaccurate measurement.) If the saw blade is not exactly perpendicular to the fence, loosen the four screws that hold the miter scale and move the miter lock handle and the scale left or right until the blade is perpendicular to the fence, as measured with the square. Retighten the four screws. Pay no attention to the reading of the miter pointer at this time.

MITER POINTER ADJUSTMENT (FIG. 5)

Unlock the miter lock handle to move the miter arm to the zero position. With the miter lock handle unlocked, allow the miter latch to snap into place as you rotate the miter arm to zero. Observe the miter pointer and miter scale shown in Figure 5. If the pointer does not indicate exactly zero, loosen the miter pointer screw holding the pointer in place, reposition the pointer and tighten the screw.

BEVEL SQUARE TO TABLE ADJUSTMENT (FIG. 4, 6, 11)

To align the blade square to the table, lock the arm in the down position with the lock down pin. Place a square against the blade, ensuring the square is not on top of a tooth. Loosen the bevel lock knob and ensure the arm is firmly against the 0° bevel stop. Rotate the 0° bevel adjustment screw with the 1/2" (13 mm) blade wrench as necessary so that the blade is at 0° bevel to the table.

FIG. 10

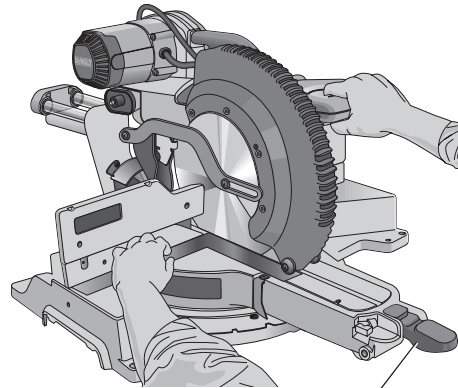

MITER LOCK HANDLE

FIG. 11

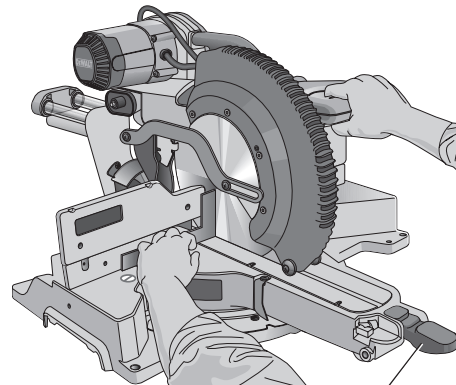

MITER LOCK HANDLE

BEVEL POINTERS (FIG. 6)

If the bevel pointers do not indicate zero, loosen each screw that holds each bevel pointer in place and move them as necessary. Ensure the 0° bevel is correct and the bevel pointers are set before adjusting any other bevel angle screws.

BEVEL STOP 45° RIGHT AND LEFT ADJUSTMENT (FIG. 4, 6)

To adjust the right 45° bevel angle, loosen the bevel lock knob and pull the 0° bevel stop to override the 0° bevel stop. When the saw is fully to the right, if the bevel pointer does not indicate exactly 45°, turn the left 45° bevel adjustment screw with the 1/2" (13 mm) blade wrench until the bevel pointer indicates 45°.

To adjust the left 45° bevel stop, first loosen the bevel lock knob and tilt the head to the left. If the bevel pointer does not indicate exactly 45°, turn the right 45° bevel adjustment screw until the bevel pointer reads 45°.

ADJUSTING THE BEVEL STOP TO 22.5° (OR 33.9°) (FIG. 4, 6)

NOTE: Adjust the bevel angles only after performing the 0° bevel angle and bevel pointer adjustment.

To set the left 22.5° bevel angle, flip out the left 22.5° bevel pawl. Loosen the bevel lock knob and tilt the head fully to the left. If the bevel pointer does not indicate exactly 22.5°, turn the crown adjustment screw contacting the pawl with a 7/16" (10 mm) wrench until the bevel pointer reads 22.5°.

To adjust the right 22.5° bevel angle, flip out the right 22.5° bevel pawl. Loosen the bevel lock knob and pull the 0° bevel stop to override the 0° bevel stop. When the saw is fully to the right, if the bevel pointer does not indicate exactly 22.5°, turn the crown adjustment screw contacting the pawl with a 7/16" (10 mm) wrench until the bevel pointer indicates exactly 22.5°.

FENCE ADJUSTMENT (FIG. 4)

⚠WARNING: To reduce the risk of serious personal injury, turn off the tool and disconnect it from the power source before attempting to move it, change accessories or make any adjustments.

In order that the saw can bevel to many bevel positions, one of the fences may have to be adjusted to provide clearance. To adjust each fence, loosen the fence adjustment knob and slide the fence outward. Make a dry run with the saw turned off and check for clearance. Adjust the fence to be as close to the blade as practical to provide maximum workpiece support, without interfering with arm up and down movement. Tighten the fence adjustment knob securely. When the bevel operations are complete, don't forget to relocate the fence.

For certain cuts, it may be desirable to bring the fences closer to the blade. To use this feature, back the fence adjustment knobs out two turns and move the fences closer to the blade past the normal limit, then tighten the fence adjustment knobs to keep the fences in this location. When using this feature, make a dry cut first to ensure the blade does not contact the fences.

NOTE: The tracks of the fences can become clogged with sawdust. If you notice that they are becoming clogged, use a brush or some low pressure air to clear the guide grooves.

GUARD ACTUATION AND VISIBILITY (FIG. 4)

⚠CAUTION: Pinch hazard. To reduce the risk of injury, keep thumb underneath the operating handle when pulling the handle down. The lower guard will move up as the operating handle is pulled down, which could cause pinching.

The lower guard on your saw has been designed to automatically uncover the blade when the arm is brought down and to cover the blade when the arm is raised.

The guard can be raised by hand when installing or removing saw blades or for inspection of the saw. NEVER RAISE THE LOWER GUARD MANUALLY UNLESS THE BLADE IS STOPPED.

NOTE: Certain special cuts of large material will require that you manually raise the guard. Refer to **Cutting Large Material** under **Special Cuts**.

The front section of the guard is louvered for visibility while cutting. Although the louvers dramatically reduce flying debris, they are openings in the guard and safety glasses should be worn at all times.

KERF PLATE ADJUSTMENT (FIG. 4)

To adjust the kerf plates, loosen the screws holding the kerf plates in place. Adjust so that the kerf plates are as close as possible without interfering with the blade's movement.

If a zero kerf width is desired, adjust the kerf plates as close to each other as possible. They can now be cut slowly with the saw blade to give the smallest gap possible between the blade and the kerf plates.

RAIL GUIDE ADJUSTMENT (FIG. 4)

Periodically check the rails for any play or clearance. The right rail can be adjusted with the set screw shown in Figure 4. To reduce clearance, use a 4 mm hex wrench and rotate the

set screw clockwise gradually while sliding the saw head back and forth. Reduce play while maintaining minimum slide force.

MITER LOCK ADJUSTMENT (FIG. 12)

The miter lock rod should be adjusted if the table of the saw can be moved when the miter lock handle is locked (down). To adjust the miter lock, put the miter lock handle in the unlocked (up) position. Using a 1/2" (13 mm) open end wrench, loosen the lock nut on the miter lock rod (Fig. 12). Using a slotted screwdriver, tighten the miter lock rod by turning it clockwise as shown in Figure 12. Turn the lock rod until it is snug, then turn counterclockwise one turn. To ensure the miter lock is functioning properly, re-lock the miter lock to a non-detented measurement on the miter scale – for example, 34° – and make sure the table will not rotate. Tighten lock nut.

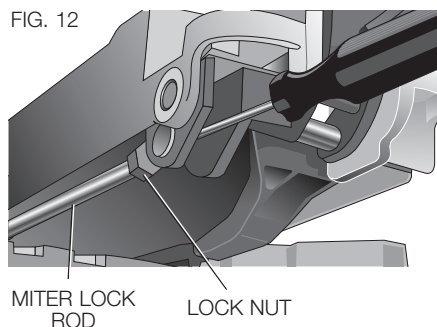

Support for Long Pieces

⚠WARNING: To reduce the risk of serious personal injury, turn off the tool and disconnect it from the power source before attempting to move it, change accessories or make any adjustments.

ALWAYS SUPPORT LONG PIECES.

Never use another person as a substitute for a table extension, as additional support for a workpiece that is longer or wider than the basic miter saw table or to help feed, support or pull the workpiece.

For best results, use the DW7080 extension work support to extend the table width of your saw, available from your dealer at extra cost. Support long workpieces using any convenient means such as sawhorses or similar devices to keep the ends from dropping.

Cutting Picture Frames, Shadow Boxes And Other Four-Sided Projects (Fig. 13, 14)

To best understand how to make the items listed here, we suggest that you try a few simple projects using scrap wood until you develop a "feel" for your saw.

Your saw is the perfect tool for mitering corners like the one shown in Figure 13. Sketch A in Figure 14 shows a joint made by using the bevel adjustment to bevel the edges of the two boards at 45° each to produce a 90° corner. For this joint the miter arm was locked in the zero position and the bevel adjustment was locked at 45°. The wood was positioned with the broad flat side against the table and the narrow edge against the fence. The cut could also be made by mitering right and left with the broad surface against the fence.

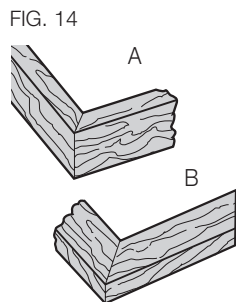
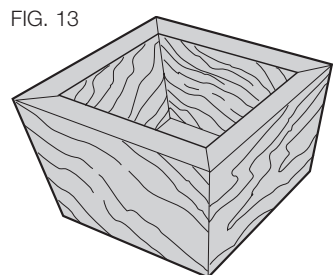

Cutting Trim Molding And Other Frames (Fig. 14)

Sketch B in Figure 14 shows a joint made by setting the miter arm at 45° to miter the two boards to form a 90° corner. To make this type of joint, set the bevel adjustment to zero and the miter arm to 45°. Once again, position the wood with the broad flat side on the table and the narrow edge against the fence.

The two sketches in Figure 14 are for four-sided objects only.

As the number of sides changes, so do the miter and bevel angles. The chart below gives the proper angles for a variety of shapes.

- EXAMPLES -

NUMBER OF SIDES	MITER OR BEVEL ANGLE
4	45°
5	36°
6	30°
7	25.7°
8	22.5°
9	20°
10	18°

The chart assumes that all sides are of equal length. For a shape that is not shown in the chart, use the following formula: 180° divided by the number of sides equals the miter (if the material is cut vertically) or bevel angle (if the material is cut laying flat).

Cutting Compound Miters (Fig. 15)

A compound miter is a cut made using a miter angle and a bevel angle at the same time. This is the type of cut used to make frames or boxes with slanting sides like the one shown in Figure 15.

NOTE: If the cutting angle varies from cut to cut, check that the bevel lock knob and the miter lock handle are securely locked. These must be locked after making any changes in bevel or miter.

The chart at the end of this manual (Table 1) will assist you in selecting the proper bevel and miter settings for common compound miter cuts. To use the chart, select the desired angle A (Fig. 15) of your project and locate that angle on the appropriate arc in the chart. From that point follow the chart straight down to find the correct bevel angle and straight across to find the correct miter angle.

Set your saw to the prescribed angles and make a few trial cuts. Practice fitting the cut pieces together until you develop a feel for this procedure and feel comfortable with it.

Example: To make a 4-sided box with 26° exterior angles (Angle A, Fig. 15), use the upper right arc. Find 26° on the arc scale. Follow the horizontal intersecting line to either side to get miter angle setting on saw (42°). Likewise, follow the vertical intersecting line to the top or bottom to get the bevel angle setting on the saw (18°). Always try cuts on a few scrap pieces of wood to verify the settings on the saw.

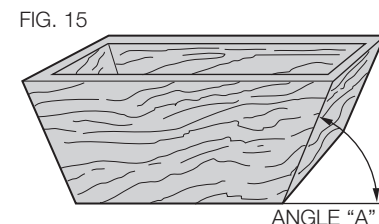

Cutting Base Molding (Fig. 16)

ALWAYS MAKE A DRY RUN WITHOUT POWER BEFORE MAKING ANY CUTS.

Straight 90° cuts:

Position the wood against the fence and hold it in place as shown in Figure 16. Turn on the saw, allow the blade to reach full speed and lower the arm smoothly through the cut.

CUTTING BASE MOLDING FROM 3" UP TO 6.75" (76 mm to 171 mm) HIGH VERTICALLY AGAINST THE FENCE

NOTE: Use the slide lock lever, shown in Figure 7, when cutting base molding measuring from 3" to 6.75" (76 mm to 171 mm) high vertically against the fence.

Position material as shown in Figure 16.

All cuts should be made with the back of the molding against the fence and with the bottom of the molding against the table.

	INSIDE CORNER	OUTSIDE CORNER
Left side	Miter left 45° Save left side of cut	Miter right 45° Save left side of cut
Right side	Miter right 45° Save right side of cut	Miter left 45° Save right side of cut

Material up to 6.75" (171 mm) can be cut as described above.

FIG. 16

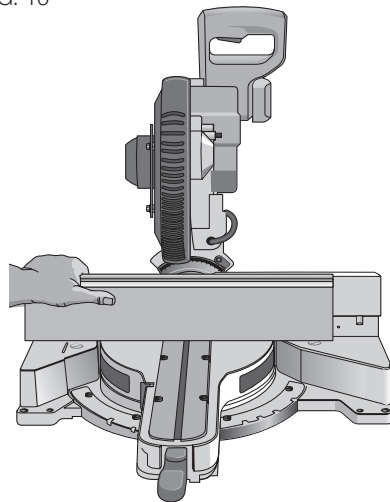

Cutting Crown Molding

Your miter saw is well suited to the task of cutting crown molding. In order to fit properly, crown molding must be compound mitered with extreme accuracy.

The two flat surfaces on a given piece of crown molding are at angles that, when added together, equal exactly 90°. Most, but not all, crown molding has a top rear angle (the section that fits flat against the ceiling) of 52° and a bottom rear angle (the part that fits flat against the wall) of 38°.

Your miter saw has special pre-set miter latch points at 31.62° left and right for cutting crown molding at the proper angle and bevel stop pawls at 33.9° left and right. There is also a mark on the bevel scale at 33.9°.

The chart below gives the proper settings for cutting crown molding. (The numbers for the miter and bevel settings are very precise and are not easy to accurately set on your saw.) Since most rooms do not have angles of precisely 90°, you will have to fine tune your settings anyway.

PRETESTING WITH SCRAP MATERIAL IS EXTREMELY IMPORTANT!

INSTRUCTIONS FOR CUTTING CROWN MOLDING LAYING FLAT AND USING THE COMPOUND FEATURES

1. Molding should lay flat with broad back surface down on saw table (Fig. 17).
2. Top of molding against fence.
3. The settings below are for all standard (U.S.) crown molding with 52° and 38° angles.

	INSIDE CORNER	OUTSIDE CORNER
Left side	Bevel left 33.9° Miter table set at right 31.62° Save left end of cut	Bevel right 33.9° Miter table set at left 31.62° Save left end of cut
Right side	Bevel right 33.9° Miter table set at left 31.62° Save right end of cut	Bevel left 33.9° Miter table set at right 31.62° Save right end of cut

When setting bevel and miter angles for all compound miters, remember that:

The angles presented for crown moldings are very precise and difficult to set exactly. Since they can easily shift slightly and very few rooms have exactly square corners, all settings should be tested on scrap molding.

FIG. 17

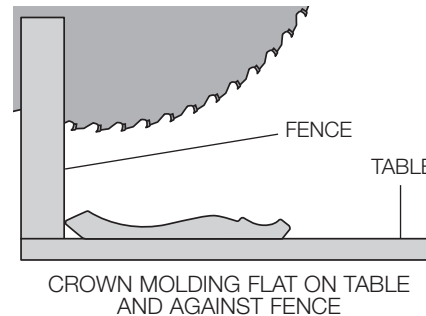
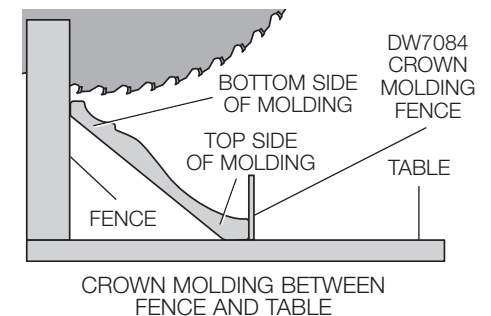

FIG. 18



PRETESTING WITH SCRAP MATERIAL IS EXTREMELY IMPORTANT!

ALTERNATIVE METHOD FOR CUTTING CROWN MOLDING

Place the molding on the table at an angle between the fence and the saw table, as shown in Figure 18. Use of the crown molding fence accessory (DW7084) is highly recommended because of its degree of accuracy and convenience (Fig. 1). The crown molding fence accessory is available for purchase from your local dealer.

The advantage to cutting crown molding using this method is that no bevel cut is required. Minute changes in the miter angle can be made without affecting the bevel angle. This way, when corners other than 90° are encountered, the saw can be quickly and easily adjusted for them. Use the crown molding fence accessory to maintain the angle at which the molding will be on the wall.

INSTRUCTIONS FOR CUTTING CROWN MOLDING ANGLED BETWEEN THE FENCE AND BASE OF THE SAW FOR ALL CUTS

1. Angle the molding so the bottom of the molding (part which goes against the wall when installed) is against the fence and the top of the molding is resting on the saw table, as shown in Figure 18.
2. The angled "flats" on the back of the molding must rest squarely on the fence and saw table.

	INSIDE CORNER	OUTSIDE CORNER
Left side	Miter right at 45° Save right side of cut	Miter left at 45° Save right side of cut
Right side	Miter left at 45° Save left side of cut	Miter right at 45° Save left side of cut

Special Cuts

NEVER MAKE ANY CUT UNLESS THE MATERIAL IS SECURED ON THE TABLE AND AGAINST THE FENCE.

ALUMINUM CUTTING (FIG. 19, 20)

ALWAYS USE THE APPROPRIATE SAW BLADE MADE ESPECIALLY FOR CUTTING ALUMINUM. These are available at your local DEWALT retailer or DEWALT service center. Certain workpieces, due to their size, shape or surface finish, may require the use of a clamp or fixture to prevent movement during the cut. Position the material so that you will be cutting the thinnest cross section, as shown in Figure 19. Figure 20 illustrates the wrong way to cut these extrusions.

Use a stick wax cutting lubricant when cutting aluminum. Apply the stick wax cutting lubricant directly to the saw blade before cutting. Never apply stick wax to a moving blade. The wax, available at most hardware stores and industrial mill supply houses, provides proper lubrication and keeps chips from adhering to the blade.

Be sure to properly secure workpiece.

Refer to **Saw Blades** under **Optional Accessories** for correct saw blade.

BOWED MATERIAL (FIG. 21, 22)

When cutting bowed material always position it as shown in Figure 21 and never like that shown in Figure 22. Positioning the material incorrectly will cause it to pinch the blade near the completion of the cut.

CUTTING PLASTIC PIPE OR OTHER ROUND MATERIAL

Plastic pipe can be easily cut with your saw. It should be cut just like wood and **CLAMPED OR HELD FIRMLY TO THE FENCE TO KEEP IT FROM ROLLING**. This is extremely important when making angle cuts.

CUTTING LARGE MATERIAL (FIG. 23)

Occasionally you will encounter a piece of wood a little too large to fit beneath the lower guard. If this occurs, simply place your right thumb on the upper side of the guard and roll the guard up just enough to clear the workpiece, as shown in Figure 23. Avoid doing this as much as possible, but if need be, the saw will operate properly and make the bigger cut. NEVER TIE, TAPE, OR OTHERWISE HOLD THE GUARD OPEN WHEN OPERATING THIS SAW.

SPECIAL SET-UP FOR WIDE CROSSCUTS (FIG. 24, 25)

Your saw can cut very wide (up to 16.1" [409 mm]) workpieces when a special set-up is used. To set the saw up for these workpieces, follow these steps:

1. Remove both left and right sliding fences from the saw and set aside. To remove them, unscrew the fence adjustment knobs several turns and slide each fence outward. Adjust and lock the miter control so that it is at 0° miter.
2. Make a platform using a piece of 1.5" (38 mm) thick particleboard or similar flat strong 1.5" thick wood to the dimensions: 14.5" x 26" (368 x 660 mm). The platform must be flat, otherwise the material could move during cutting and cause injury.
3. Mount the 14.5" x 26" (368 x 660 mm) platform to the saw using four 3" (76.2 mm) long wood screws through the holes in the base fence (Fig. 24). Four screws must be used to properly secure the material. When the special set-up is used, the platform will be cut

FIG. 19

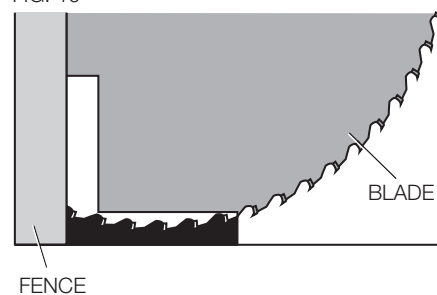

CORRECT

FIG. 20

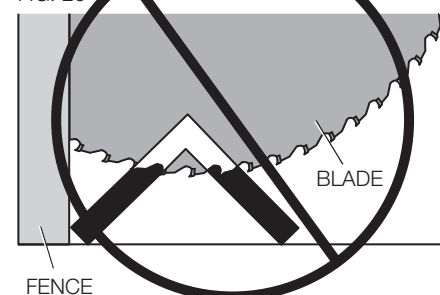

INCORRECT

FIG. 21

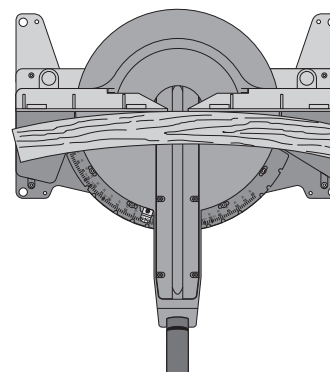

CORRECT

FIG. 22

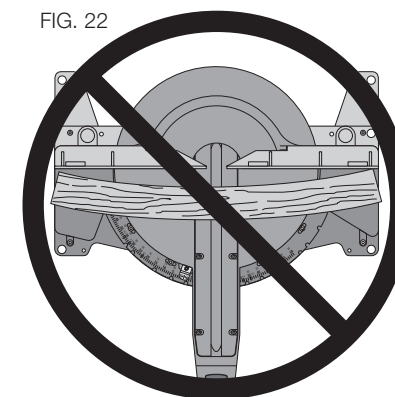

INCORRECT

FIG. 23

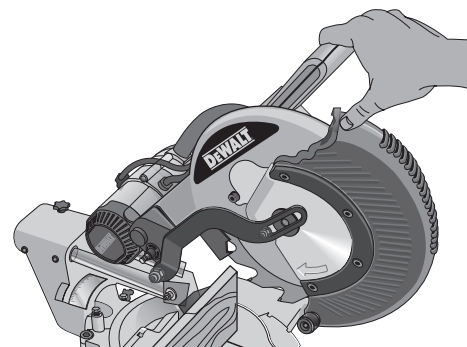
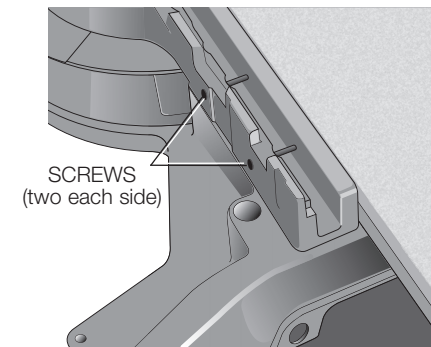

FIG. 24



into two pieces. Ensure the screws are tightened properly, otherwise material could loosen and cause injury. Ensure the platform is firmly flat on the table, against the fence, and centered evenly from left to right.

⚠WARNING: *Ensure the saw is mounted firmly to a stable flat surface. Failure to do so could cause the saw to be unstable and fall causing personal injury.*

- Place the workpiece to be cut on top of the platform mounted to the table. Ensure the workpiece is firmly against the back of the base fence (Fig. 25).
- Secure the material before cutting. Cut slowly through the material using a out-down-and-back motion. Failure to clamp securely or cut slowly could result in the material coming loose and causing injury.

After several cuts are made at various miter angles other than 0°, the platform may weaken and not properly support the work. Install a new, unused platform to the saw after presetting the desired miter angle.

⚠CAUTION: *Continued use of a platform with several kerfs may cause loss of material control and possible injury.*

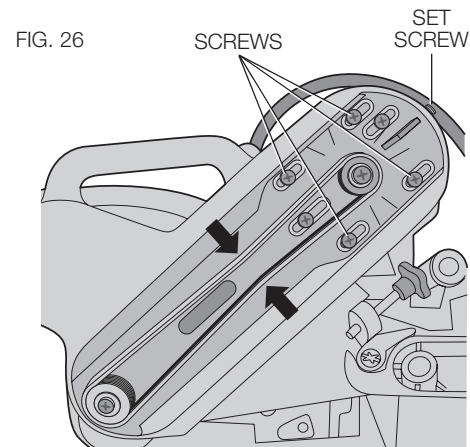
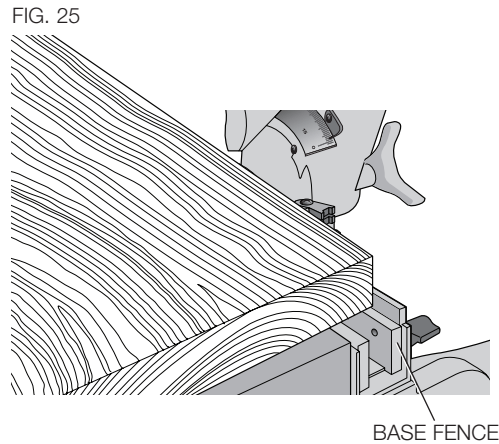

⚠WARNING: *To reduce the risk of serious personal injury, turn off the tool and disconnect it from the power source before attempting to move it, change accessories or make any adjustments.*

⚠WARNING: *To reduce the risk of serious personal injury, DO NOT touch the sharp points on the blade with fingers or hands while performing any maintenance.*

DO NOT use lubricants or cleaners (particularly spray or aerosol) in the vicinity of the plastic guard. The polycarbonate material used in the guard is subject to attack by certain chemicals.

- All bearings are sealed. They are lubricated for life and need no further maintenance.
- Periodically clean all dust and wood chips from around AND UNDER the base and the rotary table. Even though slots are provided to allow debris to pass through, some dust will accumulate.
- The brushes are designed to give you several years of use. If they ever need replacement follow the instructions under **Brushes** or return the tool to the nearest service center for repair.

Worklight Cleaning

For the best worklight performance, perform the following maintenance regularly.

- Carefully clean sawdust and debris from worklight lens with a cotton swab.
- DO NOT use solvents of any kind, they may damage the lens.
- Dust build-up can block the worklight and prevent it from accurately indicating the line of cut.
- Follow miter saw's instruction manual to remove and install blade.
- With blade removed from saw, clean pitch and build-up from blade. Pitch and debris can interfere with the worklight and prevent it from accurately indicating the line of cut.

SPECIFICATIONS	
Light source	Power LED
Worklight	3.3 V DC
Power Supply	Input: 120–240 V AC; 50/60Hz Output: 5 V DC; 0.45 A
Operating Temperature	14°F to 104°F (-10°C to 40°C)
Storage Temperature	-22°F to 176°F (-30°C to 80°C)
Environmental	Water resistant

Dust Duct Cleaning

Depending on your cutting environment, saw dust can clog the dust duct and may prevent dust from flowing away from the cutting area properly. With the saw unplugged and the saw head raised fully, low pressure air or a large diameter dowel rod can be used to clear the dust out of the dust duct.

Brushes

⚠WARNING: *To reduce the risk of serious personal injury, turn off the tool and disconnect it from the power source before attempting to move it, change accessories or make any adjustments.*

Inspect carbon brushes regularly by unplugging tool, removing the motor endcap (Fig. 4), lifting the brush spring and withdrawing the brush assembly. Keep brushes clean and sliding freely in their guides. Always replace a used brush in the same orientation in the holder as it was prior to its removal. If the brushes are worn down to approximately 1/2" (12.7 mm), the springs will no longer exert pressure and they must be replaced. Use only identical DEWALT brushes. Use of the correct grade of brush is essential for proper operation of electric brake. New brush assemblies are available at DEWALT service centers. The tool should be allowed to "run in" (run at no load) for 10 minutes before use to seat new brushes. The electric brake may be erratic in operation until the brushes are properly seated (worn in). Always replace the brush inspection cap after inspection or servicing the brushes.

While "running in" DO NOT TIE, TAPE, OR OTHERWISE LOCK THE TRIGGER SWITCH ON. HOLD BY HAND ONLY.

Troubleshooting Guide

BE SURE TO FOLLOW SAFETY RULES AND INSTRUCTIONS

TROUBLE!	WHAT'S WRONG?	WHAT TO DO
Saw will not start	1. Saw not plugged in	1. Plug in saw.
	2. Fuse blown or circuit breaker tripped	2. Replace fuse or reset circuit breaker.
	3. Cord damaged	3. Have cord replaced by authorized service center.
	4. Brushes worn out	4. Have brushes replaced by authorized service center or replace them yourself. Refer to Brushes .
Saw makes unsatisfactory cuts	1. Dull blade	1. Replace blade. Refer to Changing or Installing a New Saw Blade .
	2. Blade mounted backwards	2. Turn blade around. Refer to Changing or Installing a New Saw Blade .
	3. Gum or pitch on blade	3. Remove blade and clean with coarse steel wool and turpentine or household oven cleaner.
	4. Incorrect blade for work being done	4. Change the blade type. Refer to Saw Blades under Optional Accessories .
Blade does not come up to speed	1. Extension cord too light or too long	1. Replace with adequate size cord. Refer to Use Proper Extension Cord under Important Safety Instructions .
	2. Low house current	2. Contact your electric company.
Machine vibrates excessively	1. Saw not mounted securely to stand or work bench	1. Tighten all mounting hardware. Refer to Bench Mounting .
	2. Stand or bench on uneven floor	2. Reposition on flat level surface. Refer to Familiarization .
	3. Damaged saw blade	3. Replace blade. Refer to Changing or Installing a New Saw Blade .
Does not make accurate miter cuts	1. Miter scale not adjusted correctly	1. Check and adjust. Refer to Miter Scale Adjustment under Adjustments .
	2. Blade is not square to fence	2. Check and adjust. Refer to Miter Scale Adjustment under Adjustments .
	3. Blade is not perpendicular to table	3. Check and adjust fence. Refer to Bevel Square to Table Adjustment under Adjustments .
	4. Workpiece moving	4. Clamp workpiece securely to fence or glue 120 grit sandpaper to fence with rubber cement.
Material pinches blade	1. Cutting bowed material	1. Refer to Bowed Material under Special Cuts .

WARNING FOR YOUR OWN SAFETY READ INSTRUCTION MANUAL BEFORE OPERATING MITER SAW. KEEP HANDS OUT OF PATH OF SAW BLADE. DO NOT OPERATE SAW WITHOUT GUARDS IN PLACE. CHECK LOWER GUARD FOR PROPER CLOSING BEFORE EACH USE. ALWAYS TIGHTEN ADJUSTMENT KNOBS BEFORE USE. DO NOT PERFORM ANY OPERATION FRESHMAN, NEVER REACH IN BACK OF SAW BLADE. NEVER CROSS ARMS IN FRONT OF BLADE. TURN OFF TOOL AND WAIT FOR SAW BLADE TO STOP BEFORE MOVING WORKPIECE. CHANGING SETTINGS OR MOVING HANDS. DISCONNECT POWER BEFORE CHANGING BLADE OR SERVICING. TO REDUCE THE RISK OF INJURY, RETURN CARTRIDGE TO THE FULL REAR POSITION AFTER EACH CROSSCUT OPERATION. THINK! YOU CAN PREVENT ACCIDENTS.

ADVERTENCIA PARA SU PROPIA PROTECCIÓN, POR FAVOR LEA DETENIDAMENTE EL MANUAL DE INSTRUCCIONES ANTES DE PONER EN MARCHA LA SIERRA DE INGLETE. MANTENGA LAS MANOS FUERA DEL PASO DE LA HOJA, NO HAGA FUNCIONAR LA SIERRA SIN ANTES HABER INSTALADO LAS GUARDIAS. ASEGÚRESE QUE LA GUARDIA INFERIOR SE ENCUENTRE EN LA POSICIÓN DE CIERRE ANTES DE CADA APLICACIÓN, SIEMPRE APIRETE LAS PERLAS DE AJUSTE ANTES DE ACCIONAR LA HERRAMIENTA. JAMÁS REALICE OPERACIONES DE MANOS LIBRES. JAMÁS ALCANCE POR DETRÁS DE LA HOJA. JAMÁS CRUCE LOS BRAZOS EN FRENTE DE LA HOJA. APAGUE LA HERRAMIENTA Y ESPERE QUE LA HOJA SE DETENGA POR COMPLETO ANTES DE RETORNAR LA PIEZA DE TRABAJO. ANTES DE AJUSTAR LA SIERRA O ANTES DE MOVER LAS MANOS, DESCONECTE LA HERRAMIENTA ANTES DE PRESTARLE MANTENIMIENTO O ANTES DE CAMBIAR LA HOJA. A FIN DE REDUCIR EL RIESGO DE LESIONES PERSONALES, REGRESE EL CARRO COMPLETAMENTE PARA ATRAS DESPUÉS DE CADA CORTE TRANSVERSAL. USE EL SENTIDO COMÚN! USTED PUEDE EVITAR LOS ACCIDENTES.

AVERTISSEMENT PAR MESURE DE SÉCURITÉ, LIRE LE GUIDE D'UTILISATION AVANT DE SE SERVIR DE LA SCIE À ONGLETS. ÉLOIGNER LES MAINS DE LA TRAJECTOIRE DE LA LAME. NE PAS UTILISER LA SCIE SANS LES PROTECTEURS EN PLACE. VÉRIFIER LA FERMETURE APPROPRIÉE DU PROTECTEUR INFÉRIEUR AVANT CHAQUE UTILISATION. TOUJOURS SERRER LES BOUTONS DE RÉGLAGE AVANT CHAQUE UTILISATION. NE PAS EFFECTUER DE TRAVAUX À MAIN LIBRE. NE JAMAIS S'ÉTIRER VERS L'ARRIÈRE DE LA LAME DE LA SCIE. NE JAMAIS SE CRUISEZ LES BRAS À L'AVANT DE LA LAME. METTRE L'OUTIL HORS TENSION ET ATTENDRE L'IMMOBILISATION COMPLÈTE DE LA LAME AVANT DE DÉPLACER LA PIÈCE À OUVRIER. DE MOUVREZ LES RÉGLAGES DE LA SCIE OU DE DÉPLACER SES MAINS, DÉBRANCHEZ L'OUTIL AVANT DE REMPLACER LA LAME OU DE FAIRE L'ENTRETIEN DE LA SCIE. AFIN DE MINIMISER LES RISQUES DE BLESSURES, RETOURNEZ LE CARROU À SA POSITION ARRIÈRE COMPLÈTE APRES CHAQUE COUPE TRANSVERSALE. A L'AIDÉ DE PENSER! ON PEUT PRÉVENIR LES ACCIDENTS.

PROPERLY SECURE BRACKET WITH BOTH SCREWS BEFORE USE. ASEGURE LA MENSULA DEBIDAMENTE CON AMBOS TORNILLOS ANTES DE PONER EN MARCHA LA HERRAMIENTA. BIEN FIXER LE SUPPORT À L'AIDÉ DES DEUX VIS AVANT UTILISATION.

DWS780 12" (305mm) DOUBLE BEVEL SLIDING COMPOUND MITER SAW

WARNING/ADVERTENCIA/AVERTISSEMENT

FOR YOUR OWN SAFETY, READ INSTRUCTION MANUAL BEFORE OPERATING MITER SAW. WHEN SERVICING, USE ONLY IDENTICAL REPLACEMENT PARTS. DO NOT EXPOSE TO RAIN OR USE IN DAMP LOCATIONS. ALWAYS USE PROPER EYE AND RESPIRATORY PROTECTION. PARA SU PROPIA SEGURIDAD, LEA DETENIDAMENTE EL MANUAL DE INSTRUCCIONES ANTES DE PONER EN MARCHA LA SIERRA DE INGLETE. A LA HORA DE PRESTAR MANTENIMIENTO, SE DEBERÁ UTILIZAR SOLAMENTE PIEZAS BIEN IDENTICAS DE REEMPLAZO. NO EXPONGA LA HERRAMIENTA A LA LLUVIA NI LA HAGA FUNCIONAR EN LOS LUGARES HUMEDOS. SIEMPRE SE DEBERÁ LLEVAR LA PROTECCIÓN APROPIADA PARA LA VISTA Y PARA LAS VIAS RESPIRATORIAS. PAR MESURE DE SÉCURITÉ, LIRE LE GUIDE D'UTILISATION AVANT DE SE SERVIR DE LA SCIE À ONGLETS. LORS DES TRAVAUX D'ENTRETIEN, UTILISER QUE DES PIÈCES DE RÉPLACEMENT IDENTIQUES. NE PAS EXPOSER L'OUTIL À LA PLUIE NI S'EN SERVIR DANS DES ENDROITS HUMIDES. TOUJOURS PORTER DE L'ÉQUIPEMENT DE PROTECTION OCULAIRE ET RESPIRATOIRE APPROPRIÉ.

DHWALT INDUSTRIAL TOOL CO., BALTIMORE, MD, 21286 USA
FOR SERVICE INFORMATION, CALL 1-800-4-DHWALT www.DHWALT.com



ALWAYS ADJUST FENCE PROPERLY BEFORE USE. CLAMP SMALL PIECES BEFORE CUTTING. SEE MANUAL. AJUSTE LA CRUIA DEBIDAMENTE ANTES DE UTILIZAR LA HERRAMIENTA. ASEGURE LAS PIEZAS PEQUEÑAS ANTES DE CORTARLAS. CONSULTE EL MANUAL. TOUJOURS RÉGLER LE GUIDE AVANT UTILISATION. FIXER LES PETITES PIÈCES AVANT DE LES SCIER. CONSULTEZ LE GUIDE D'UTILISATION.

TABLE 1: COMPOUND MITER CUT

(POSITION WOOD WITH BROAD FLAT SIDE ON THE TABLE AND THE NARROW EDGE AGAINST THE FENCE)

